

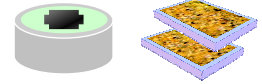

1.03.06 MULTI TURNABLE POLISHING MACHINE



CUTTING / CORING

COATING / EMBEDDING

BONDING

GRINDING

LAPPING

POLISHING



USE

The study of materials in geology often requires the taking of thin slices or the levelling of the samples on their holders before they are ground or polished, for examination in optical microscopy, microphotography, spectrometry, micro-wave, scanning or transmission microscopy.

The samples taken are approximately 4 to 10 cm².

Each polishing station can work with a aluminium or cast polishing plate Ø200, Ø250 or Ø300mm.

CHARACTERISTICS

Electrical

230V single phase (variable speed motor)
Power : 0,4 kW (single station)
Power : 0,8 kW (double station)

Water supply

Water supply Ø 12 mm
Flexible connection to the network
Shower for rinsing the part while polishing

Stop at the foot

In order to have both hands, the operator controls the stop or start-up of the tray.

Watering (1 per station)

By hose in the centre of the tray or
By multijet horizontal ramp
A solenoid valve shuts off the water on the machine when it is turned off.

Evacuation

To the waste water network, by line Ø 40 mm. to the right or left of the table.

 120 Kg

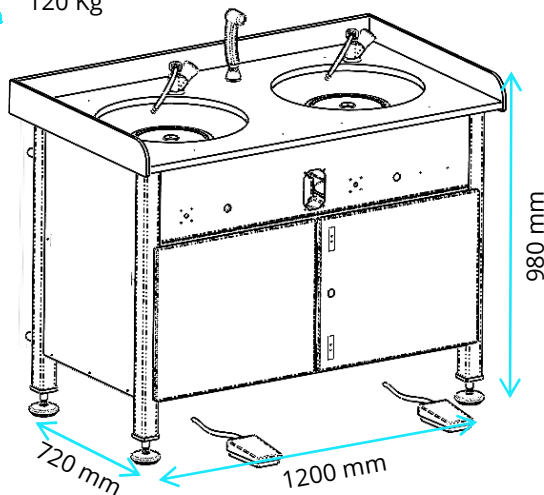

Updated in august 2020

AERI BROTLAB

230 / 250 route de Savignies - 60650 LE MONT SAINT ADRIEN - FRANCE
Tel : + 33 (0)3 44 82 88 88 - Fax : +33 (0)3 44 13 02 2 - Email : commercial@brotlab.com
SAS capital de 300 000 € - Siret : 40278098500055

BROTLAB