



# 1.03.27 GRINDING MACHINE FOR PLUGS



CUTTING / CORING

COATING / EMBEDDING

BONDING

GRINDING

LAPPING

POLISHING

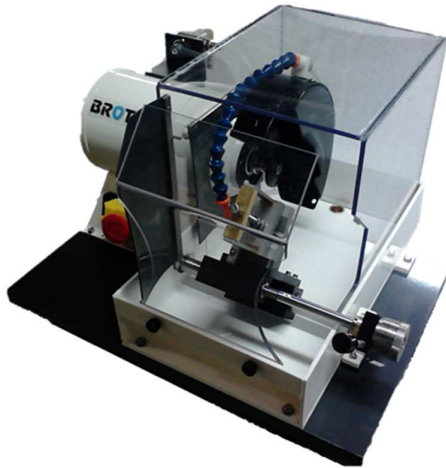

### UTILISATION

The grinding machine 1 03 27 is a compact bench machine designed for the grinding of the two faces of little cylindrical samples (plugs).

The machine uses a diamond grinding wheel with glass-binder D46 ø 150 mm. The sample, clamped on a specific device, is mounted on an oscillating sample holder.

The turn of the set sample / sample holder is done without unclamping the sample. This will allow a perfect parallelism of the two faces.

The watering (by flexible pipe) is directed to the wheel. A device including a micrometer controls the feed of the sample to grind.

A polypropylene tank collect the cooling water and the mud produced by the grinding process.

A front protection device prevent splashes.

### CHARACTERISTICS

#### Electrical

- Motor 0,5 CV, 2950 tr/min (230/400V three phase 50-60 Hz) (single phase 230V 50Hz in option)
- Emergency stop

#### Wheel

Diamond grinding wheel with glass binder D46 ø 150 mm

#### Watering

by flexible pipe with stop cock.

Water in: ø12mm

Water out: ø25mm

#### Capacity

Plugs up to ø38mm (1.5").

#### Option

Diamond grinding wheel with glass binder D30 ø 150 mm

single phase 230V 50Hz



25 Kg

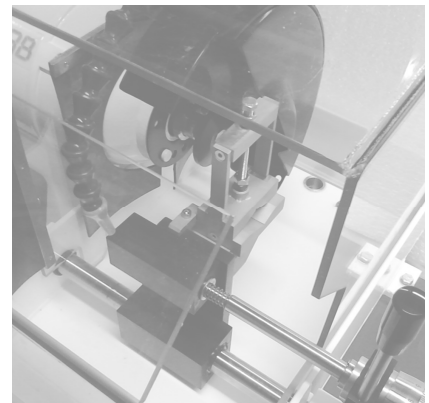
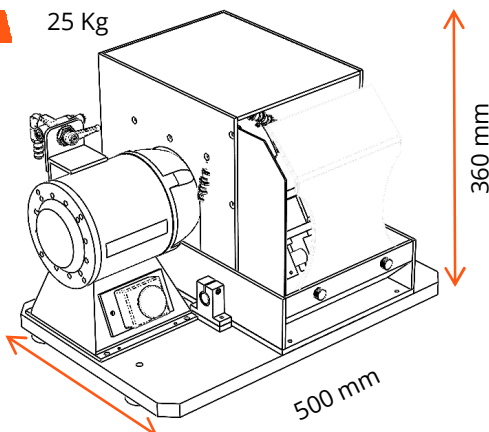

Updated in august 2020

AERI BROTLAB

230 / 250 route de Savignies - 60650 LE MONT SAINT ADRIEN - FRANCE  
Tel : + 33 (0)3 44 82 88 88 - Fax : +33 (0)3 44 13 02 2 - Email : commercial@brotlab.com  
SAS capital de 300 000 € - Siret : 40278098500055

**BROTLAB**