

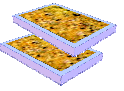

# 1.03.23 COMPACT GRINDING MACHINE FOR THIN SECTION



CUTTING / CORING

COATING / EMBEDDING

BONDING

GRINDING

LAPPING

POLISHING



### UTILISATION

The grinding machine 1 02 23 is a compact bench machine, made to grind the samples bonded on their glass plate.

The grinding post uses a diamond grinding wheel grain D30 Ø150mm.

The sample, bonded on his object holder glass plate, is assembled on an oscillating object holder.

This sample holder is able to receive sections 30x45 or 45x60 (other dimension on request).

The watering (by flexible pipe) is directed to the wheel. The slicing wished thickness is determined with a device with micrometric screw.

The polypropylene tray recovers the irrigation water and the sludge produced. A front housing prevents the splashing of the operator.

A water discharge with a flexible pipe is provided.

### CHARACTERISTICS

#### Electrical

- Motor 0.5 HP, 2950 rpm (230/400V Three-phase), with sealed bearings
- Emergency stop

#### Grinding wheel

Diamond grinding wheel with glass binder D30 Ø150mm.

#### Watering

By flexible pipe with shut-off valve.  
Water supply Ø12mm  
Water discharge Ø25mm

#### Option

single phase 230V 50 Hz



25 Kg

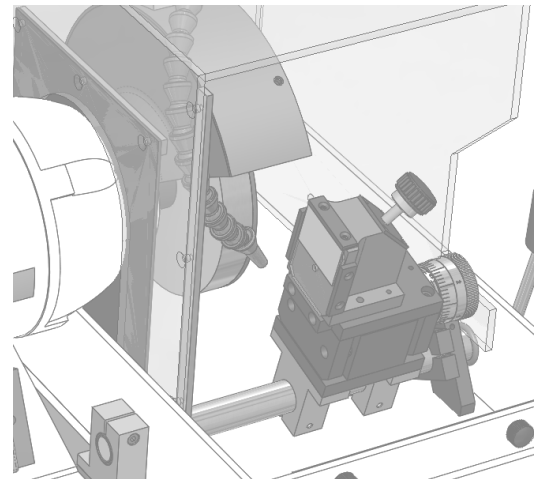
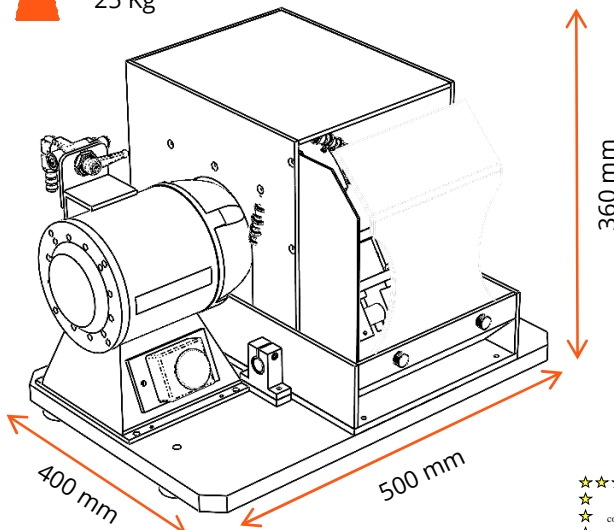

Updated in august 2020

AERI BROTLAB

230 / 250 route de Savignies - 60650 LE MONT SAINT ADRIEN - FRANCE  
Tel : + 33 (0)3 44 82 88 88 - Fax : +33 (0)3 44 13 02 2 - Email : commercial@brotlab.com  
SAS capital de 300 000 € - Siret : 40278098500055

**BROTLAB**