

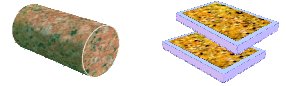

# 1.02.04 CUTTING & SLABBING SAW



CUTTING / CORING

COATING / EMBEDDING

BONDING

GRINDING

LAPPING

POLISHING



### DESCRIPTION

**Very strong machine designed to pick up samples in various stones.**

It can make dry cut (with exhauster) or wet cut with water supply or recycling tank. The adjustable depth spindle can receive all diamond discs from 300 mm to 500 mm diameter.

The table with four bronze rolls runs on two prismatic slides.

### CHARACTERISTICS

#### Electrical

- Motor IP 55 - 4 HP (400V. three-phase)
- Electrical protection incorporated in the rotation control
- Knee Emergency Stop

#### Spindle

- Spindle speeds: 960/ 1440/ 2160 tr/min after groove change in pulleys
- Ø16 (h6)

#### Option

- Housing for disc Ø500mm
- 50mm riser for disc Ø500mm

#### Lubrication

- Water supply: Ø12 mm
- Water discharge: Ø40 mm

#### Structure of the machine

- Polypropylene container tray
- Cast iron table, solid and stable
- Lateral and rear spray device

#### Disc

- Disc cover housing for Disk Ø350 or Ø400mm
- Supplied disc: Diamond disc with continuous rim ventilated for all rock types
- Height adjustable disc position

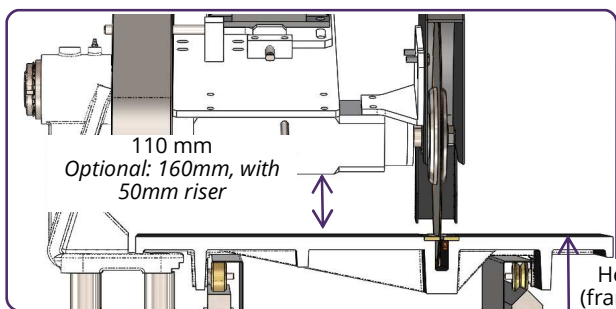

280 Kg

Height 1000 mm (frame with adjustable feet)

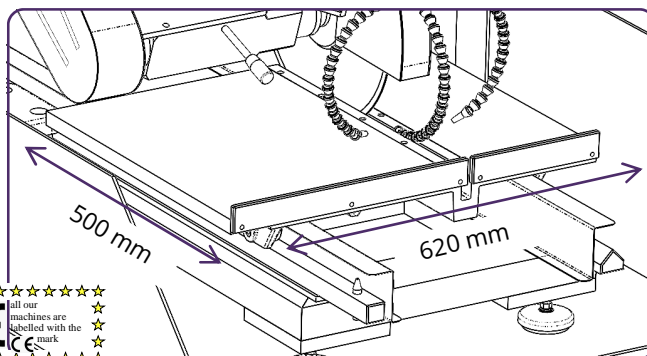
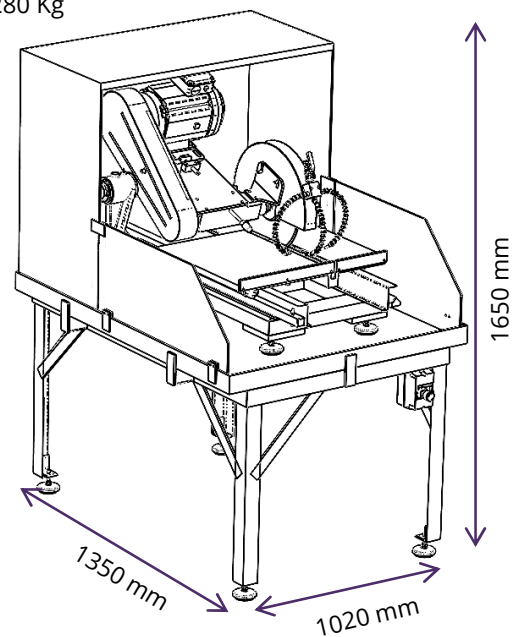

Updated in august 2020

**AERI BROTLAB**

230 / 250 route de Savignies - 60650 LE MONT SAINT ADRIEN - FRANCE  
Tel : + 33 (0)3 44 82 88 88 - Fax : +33 (0)3 44 13 02 2 - Email : commercial@brotlab.com  
SAS capital de 300 000 € - Siret : 40278098500055

**BROTLAB**